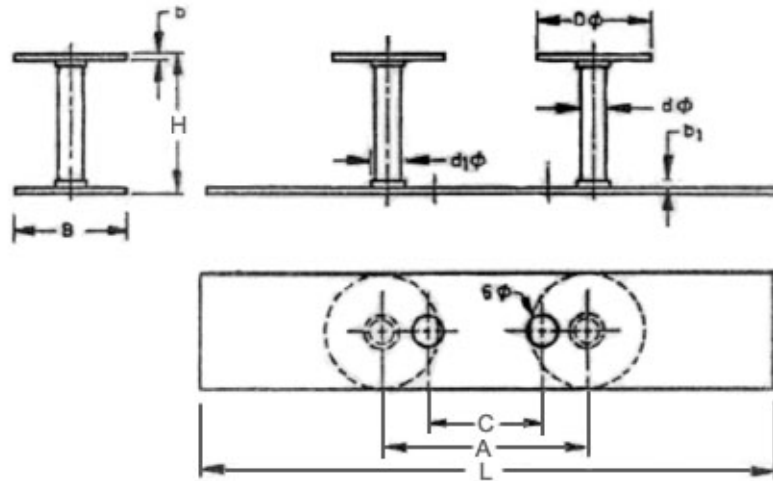

TABLE 6 DIMENSIONS OF TWO COLUMN CHAPLETS
(Clauses 4.1 and 4.1.1)

All dimensions in millimetres.



VARIANT 3

With round head, round column and rectangular bottom plate

H		L	A	B	C	D	d	d_1	b	b_1
Nominal	Tolerance									
10	+0.5 -0.14	100	40	20	20	20	4	6	0.8	1
12										
14										
16										
18										
20	+0.6 -0.14	125	45	25	25	25	5	7	1	1.5
22										
24										
25										
30										
35	+0.8 -0.12	150	50	40	35	40	6	8	1.2	2
40										
50										